

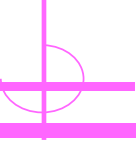

Faculty of Industrial Technology

Suan Sunandha Rajabhat University



สื่อการสอน วิชา องค์กรประกอบคอมพิวเตอร์และการเชื่อมต่อ CPE2401

ผศ.ดร.พรภวิษย์ บุญศรีเมือง

Combinational Logic Circuits

- Implementation of Logic Diagrams from Boolean Expressions
- Using NAND and NOR gates
- Using NAND and NOR gates for the inversion operation
- Implementation of DeMorgan's theorem
- Implementation of the XOR
- Implementation of the XOR function with NAND gate only
- Implementation of the Boolean expression

Implementation of the Boolean expression

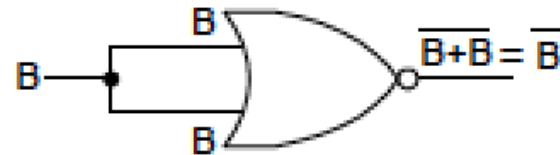
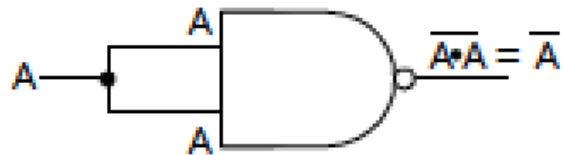
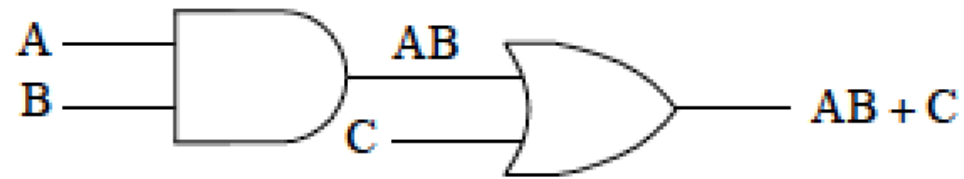

Implementation of DeMorgan's theorem

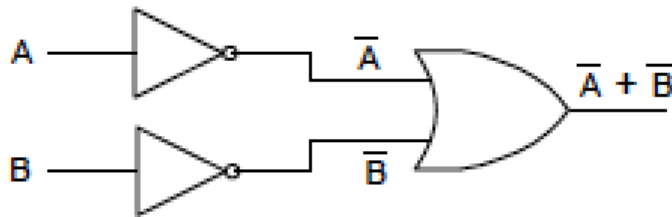
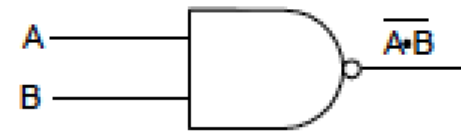

Implementation of the XOR function with AND gates

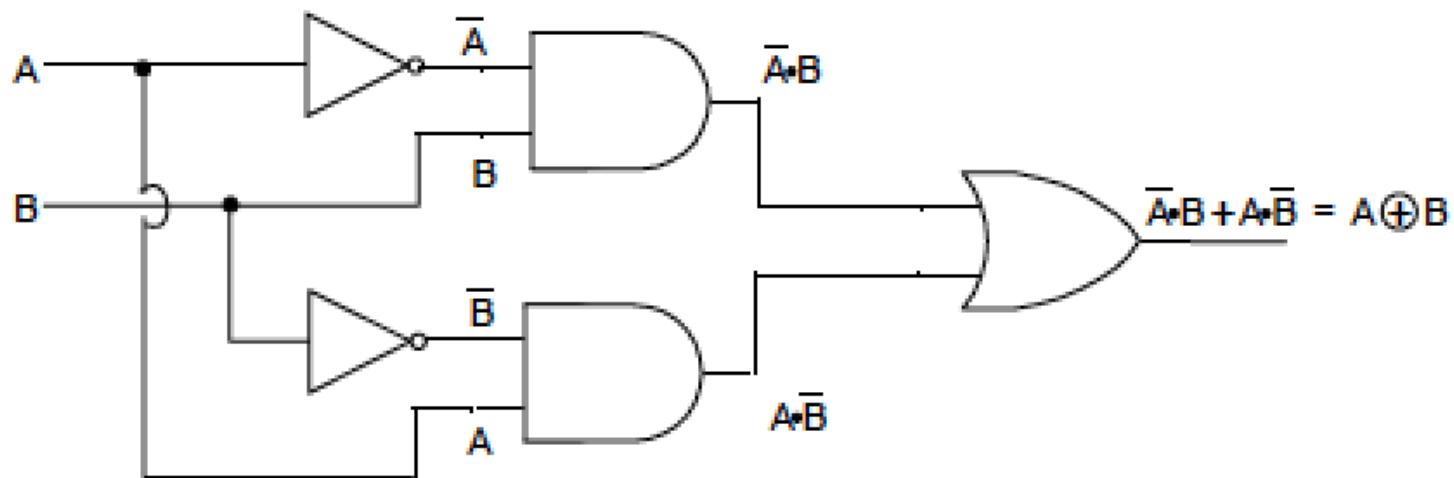

Implementation of the XOR function with NAND gates only

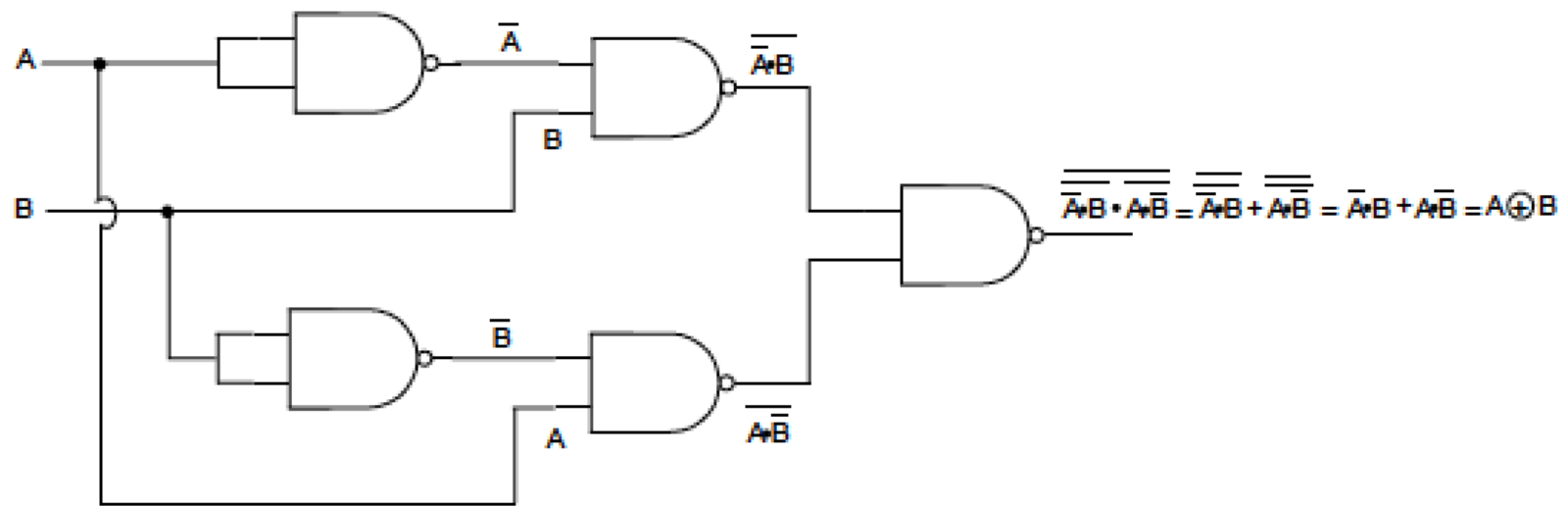

Implementation of the Boolean expression

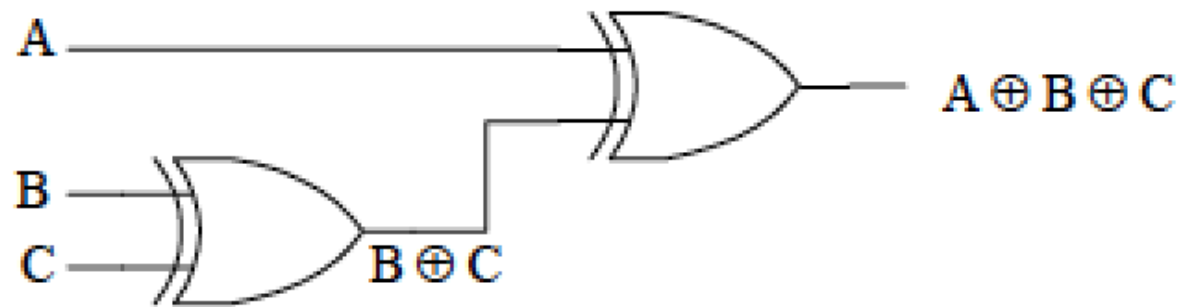

Implementation of the OR operation

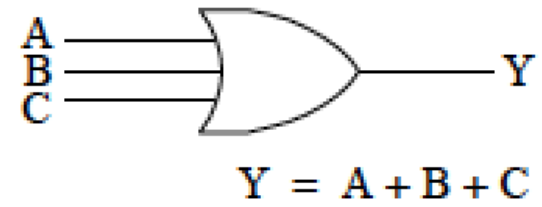
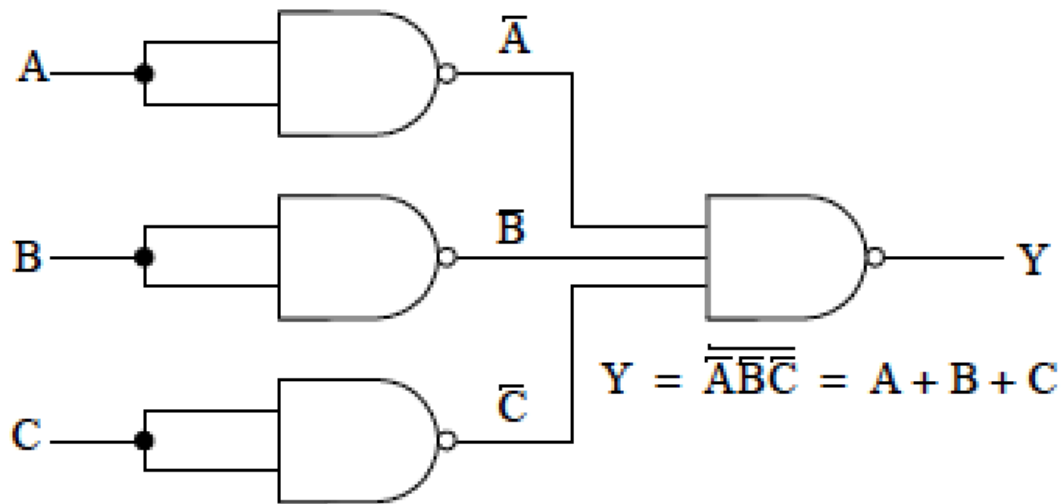

Implementation of the AND operation

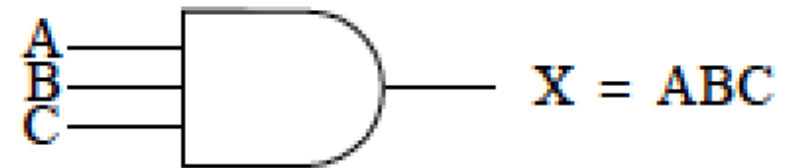
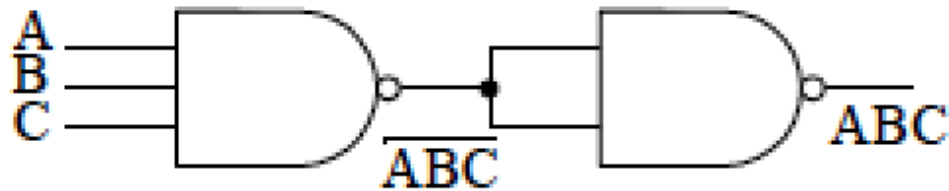

Implementation of the AND & NOR

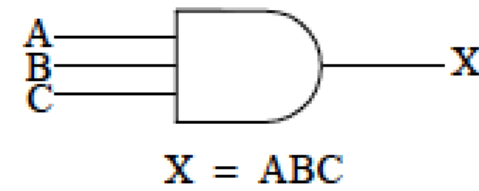
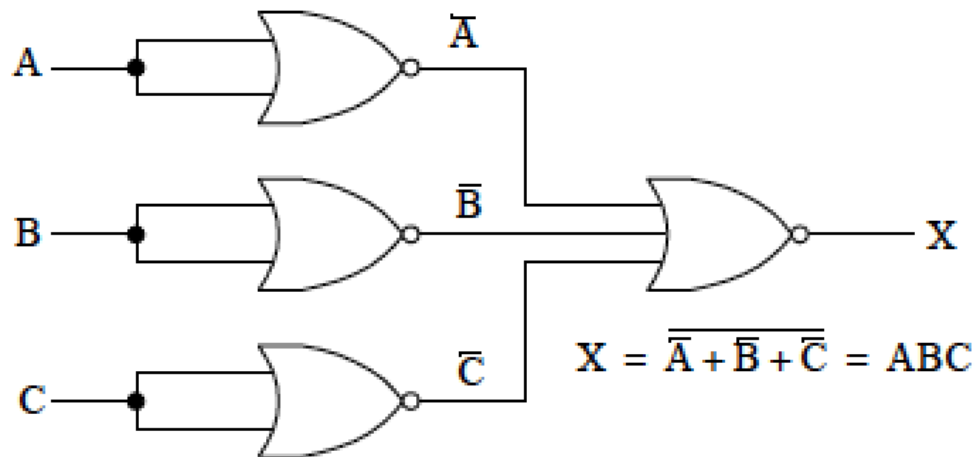

Implementation of the OR & NOR

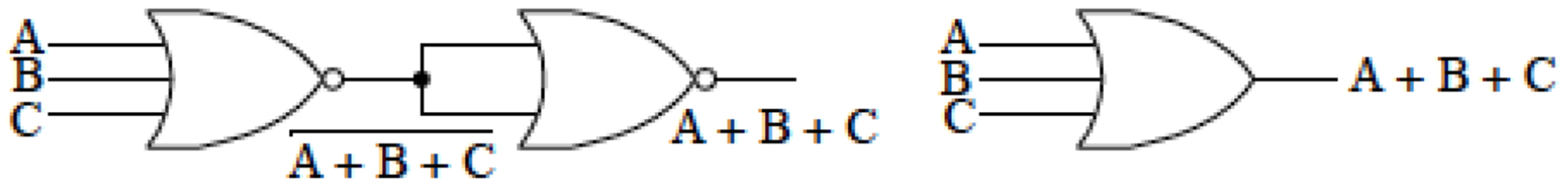

Implementation of the AND OR & Inverters

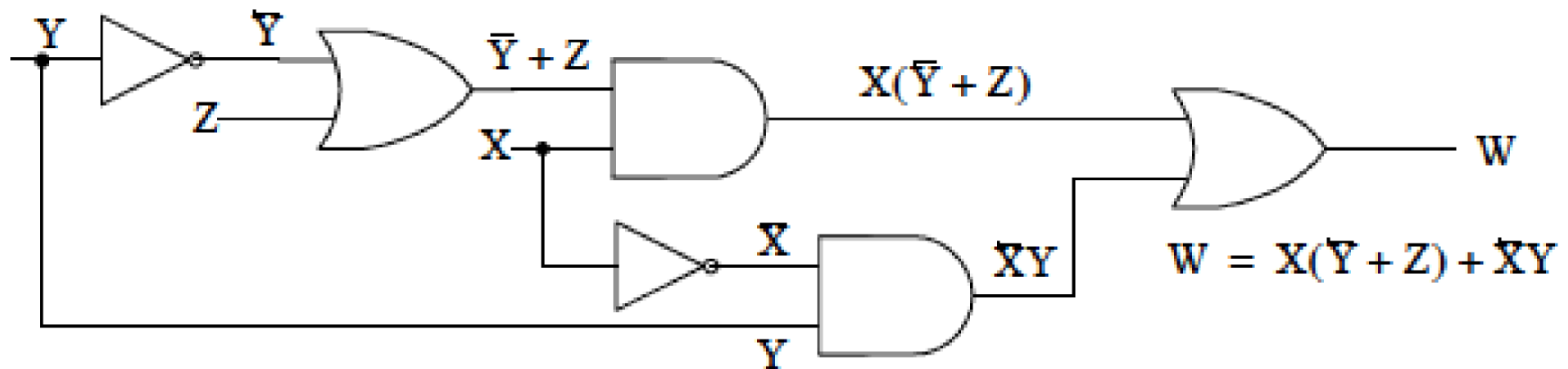

Implementation of the NAND gates

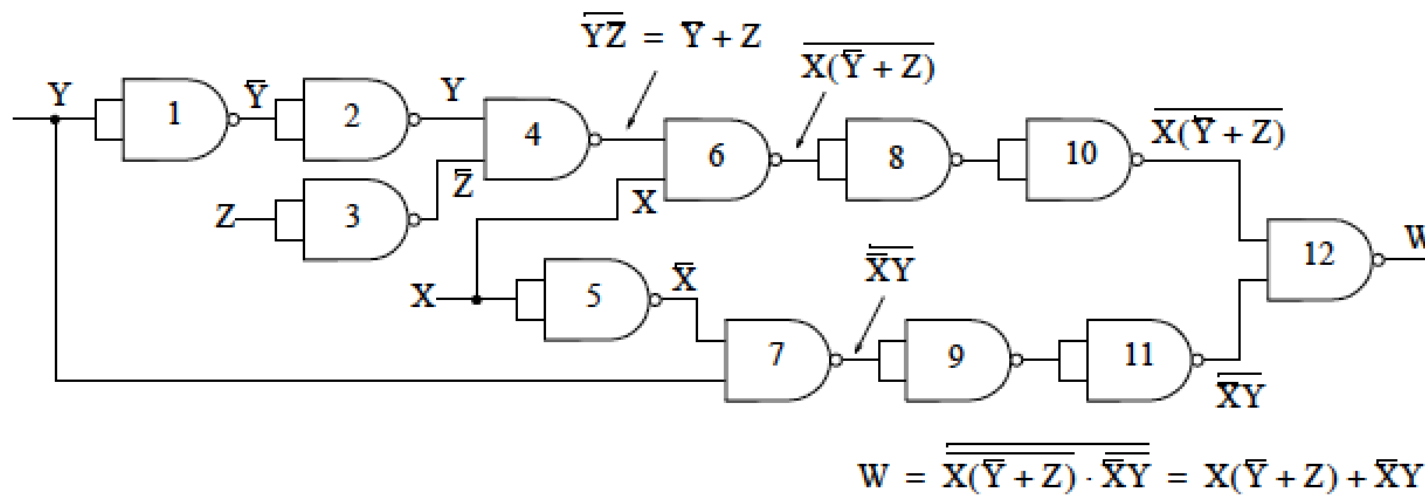

Implementation of the NAND

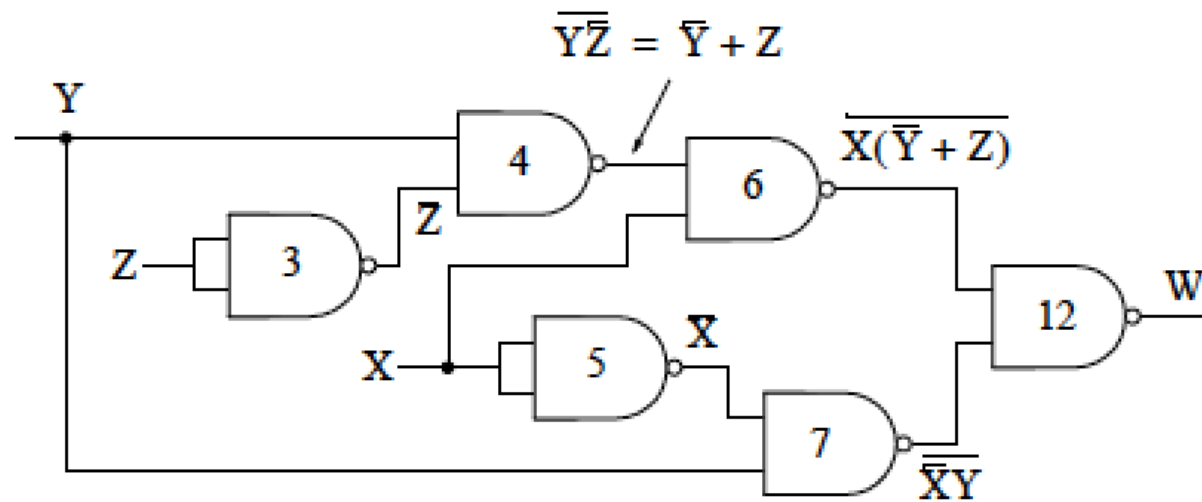

$$W = \overline{\overline{X(\overline{Y} + Z)} \cdot \overline{XY}} = X(\overline{Y} + Z) + \overline{XY}$$

Implementation of the AND OR & Inverters

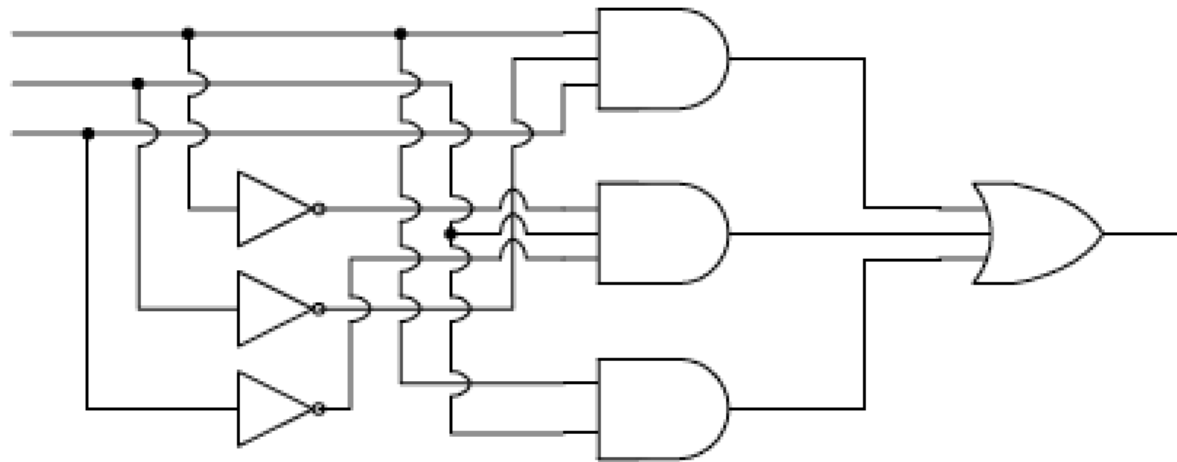

Implementation of NOR - unsimplified

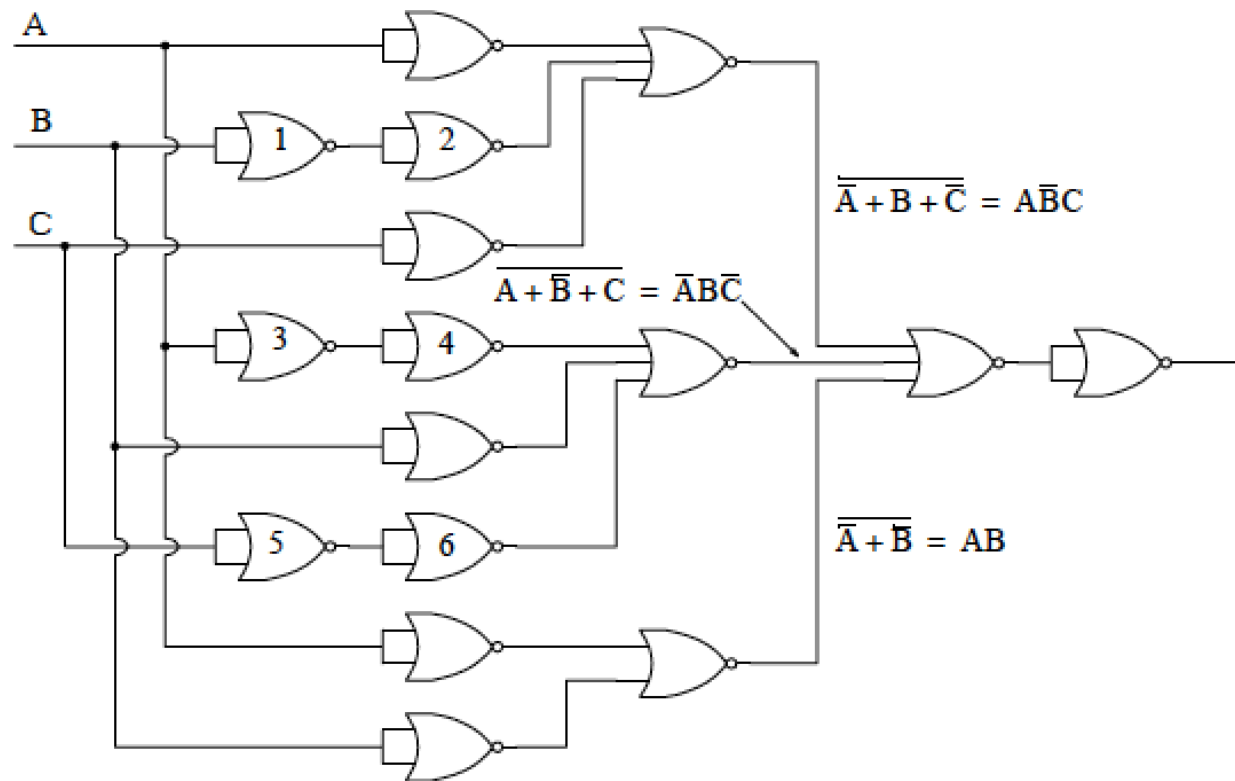

Implementation of NOR - simplified

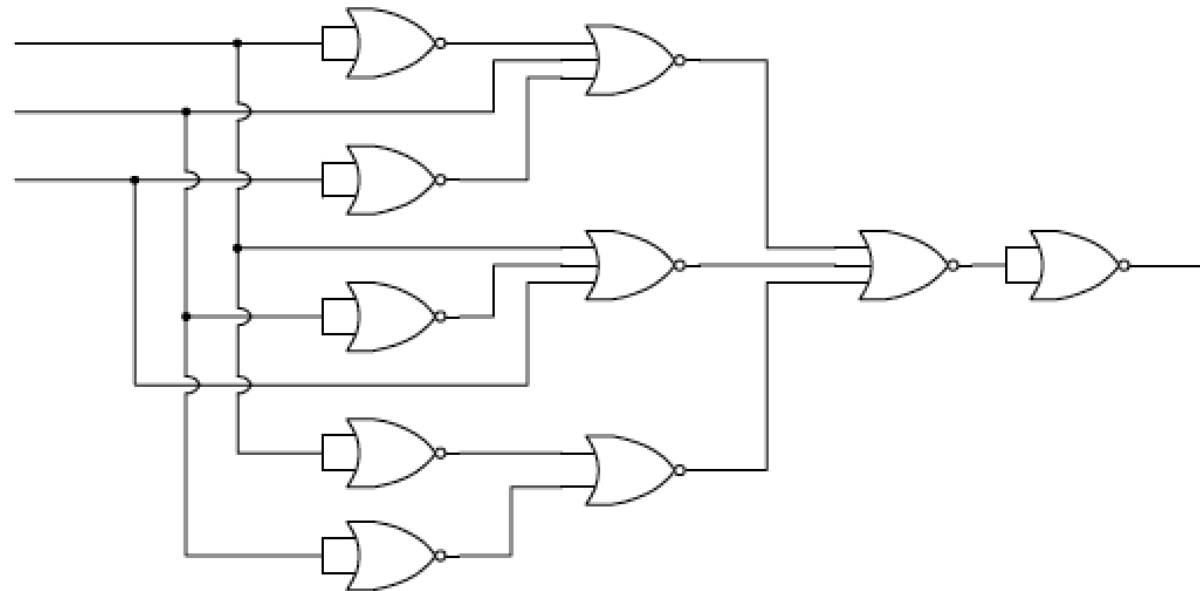

ตัวอย่าง

$$D = \bar{A}BC + A\bar{B}C + ABC + B\bar{C}.$$

$$\begin{aligned} D &= \bar{A}BC + ABC + A\bar{B}C + ABC + B\bar{C} \\ &= BC(A + \bar{A}) + AC(B + \bar{B}) + B\bar{C} \\ &= BC + AC + B\bar{C} \\ &= B(C + \bar{C}) + AC \\ &= B + AC \end{aligned}$$



Output of the gates of logic

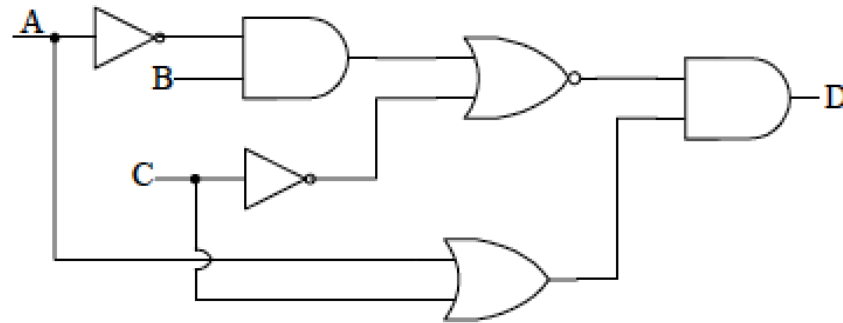

ลอจิกอย่างง่าย

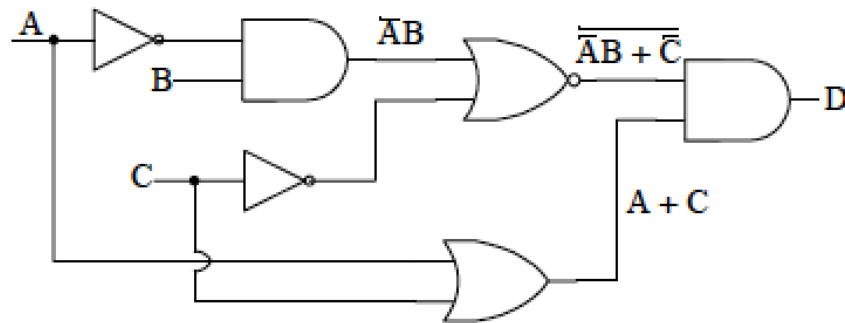

$$\begin{aligned}
 D &= (\overline{AB + C})(A + C) = (\overline{ABC})(A + C) = [(A + \overline{B})C](A + C) \\
 &= (A + \overline{B})(AC + CC) = (A + \overline{B})(AC + C) = AAC + AC + A\overline{B}C + \overline{B}C \\
 &= AC + AC + \overline{B}C(A + 1) = AC + \overline{B}C(1) = AC + \overline{B}C \\
 &= (A + \overline{B})C
 \end{aligned}$$

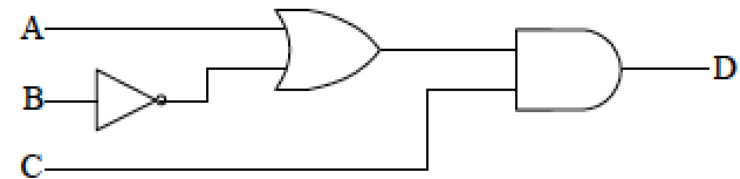

Input/Output Waveforms สัญญาณของรูปคลื่น

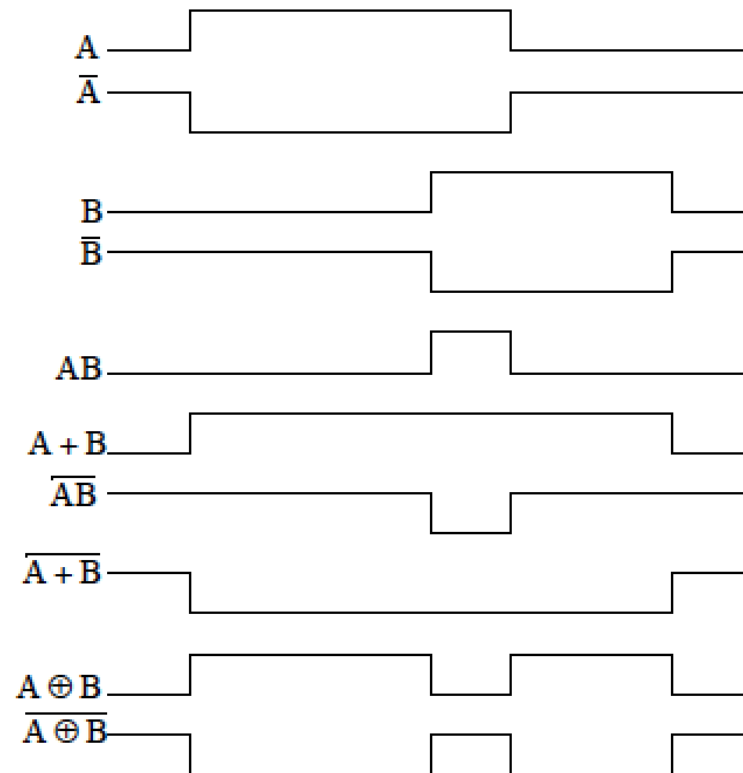

Input/Output Waveforms สัญญาณของรูปคลื่น

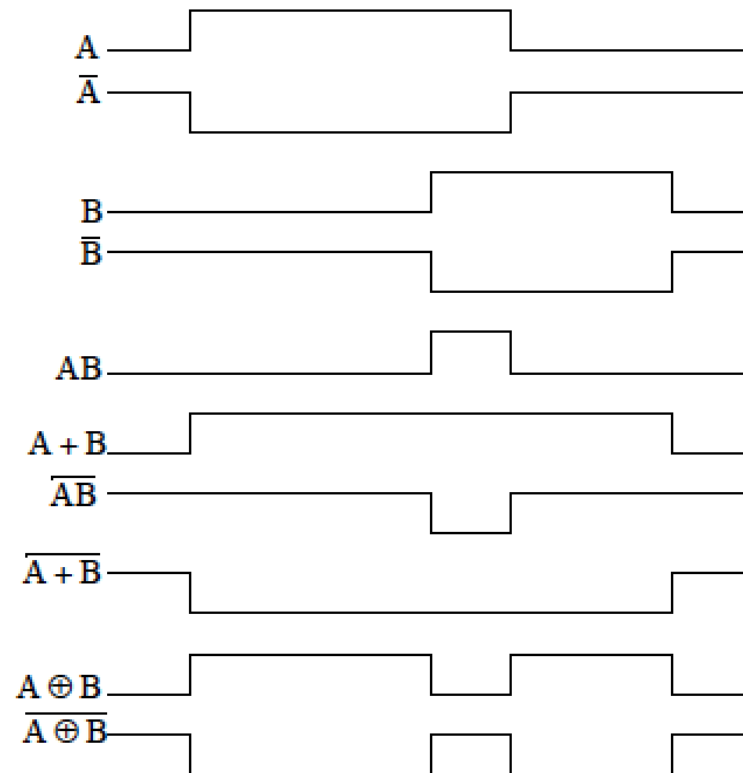

วงจรรวมของลอจิก

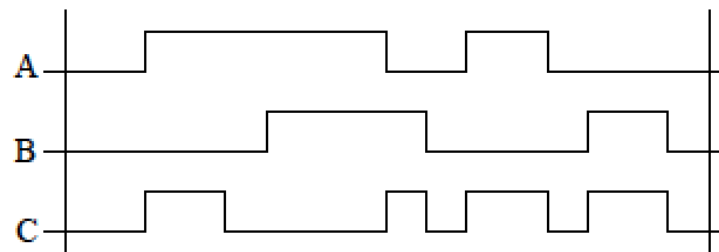
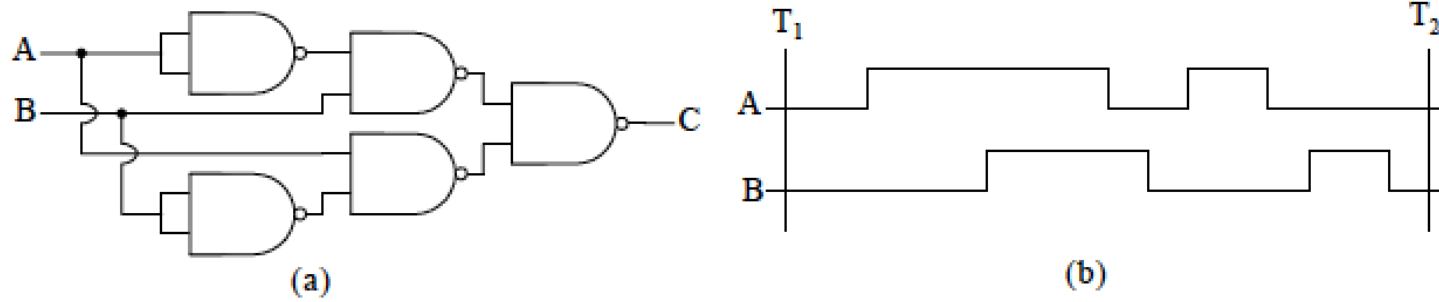

หนังสืออ้างอิง Ref.
(Required Text)

- Steven T. Karris .(2005). Digital Circuit Analysis and Design with an Introduction to CPLDs and FPGAs: Orchard Publications.