

Plotting Ohm's Law

- ⌘ If we write Ohm's Law in the manner of a straight line equation we get:

$$I = (1/R).E + 0 \quad - \quad \text{Ohm's Law}$$

- ⌘ This shows that the slope of the line is equal to $1/R$ or that $R = \Delta V / \Delta I$

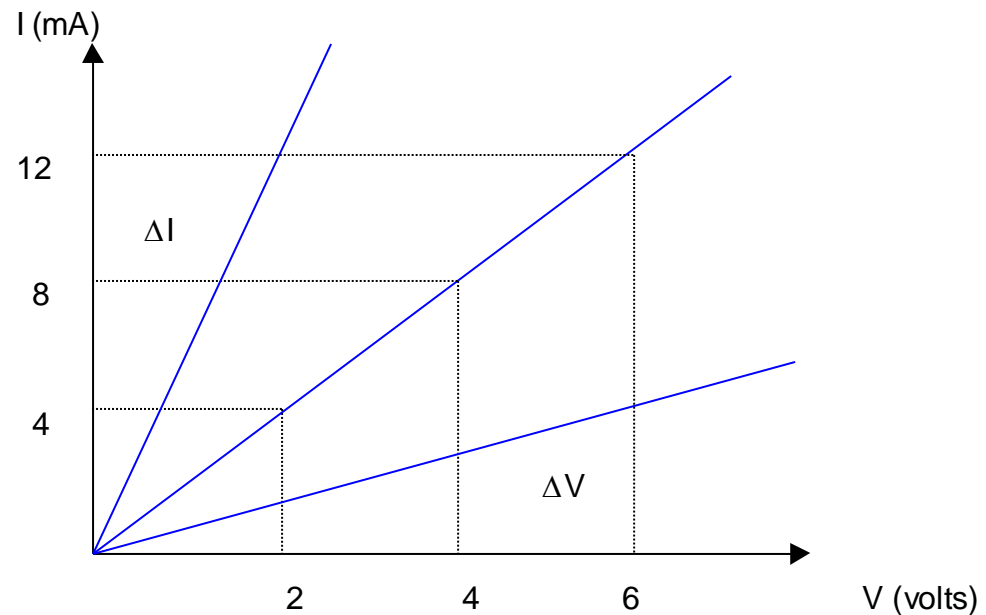

Series Circuits

- ⌘ A circuit is any number of components joined at terminal points. Providing at least one **closed path** which charge can flow through.
- ⌘ Two components are in **series** if they have only **one point in common** that is not connected to other current carrying components.
- ⌘ In a **series** circuit, the **current** is the **same** through each series component.

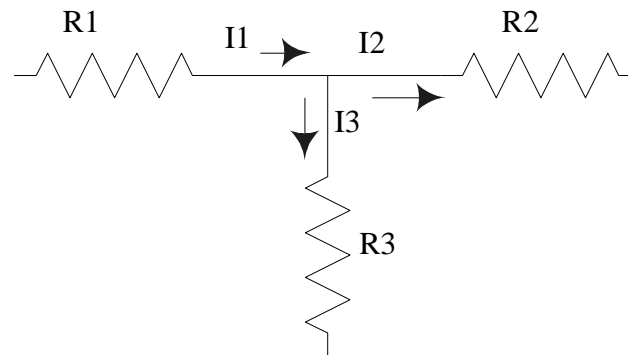
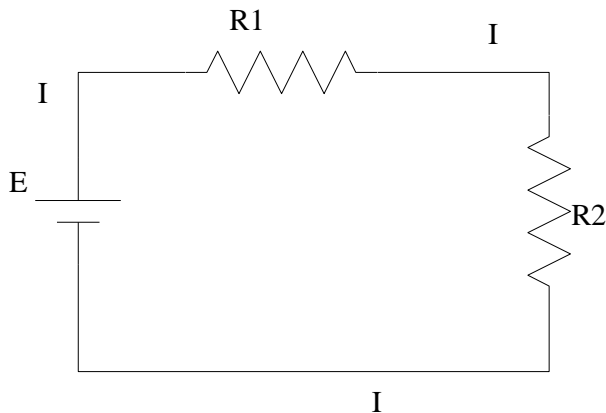

Series Resistors

⌘ To find the total resistance of N resistors in series use:

$$R_T = R_1 + R_2 + R_3 \dots + R_N$$

⌘ Once the total resistance is known, the current is:

$$I = E/R_T$$

⌘ and the voltage across each resistor is:

$$V_1 = IR_1, V_2 = IR_2, V_3 = IR_3 \text{ etc.}$$

⌘ Find the total resistance, total current and the voltages V_1 , V_2 and V_3 .

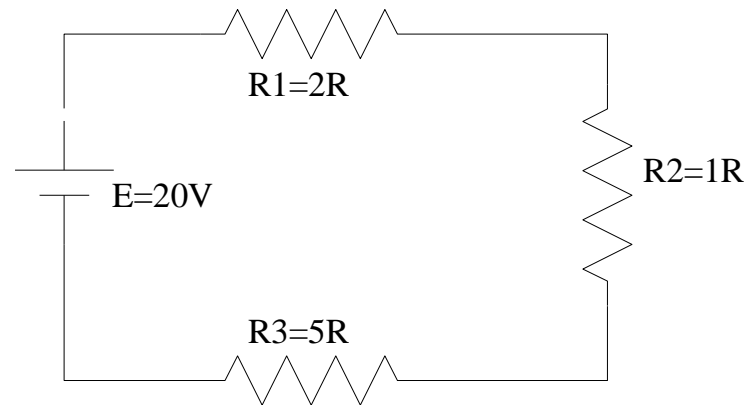

Voltage Sources in Series

- ⌘ Voltage sources **CAN** be connected in series
- ⌘ Simply **add** the sources with the **same polarity** and **subtract** the sources with the **opposite polarity**.
- ⌘ $E_T = E_1 + E_2 + E_3$

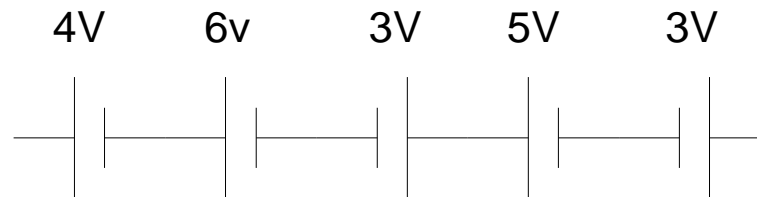

Kirchhoff's Voltage Law (KVL)

⌘ KVL states that the sum of the potential rises and drops around a closed loop is zero.

$$\sum_o V_{\text{rises}} + \sum_o V_{\text{drops}} = 0 \quad \text{or} \quad \sum_o V_{\text{rises}} = \sum_o V_{\text{drops}}$$

⌘ Determine the unknown voltages for these circuits using KVL.

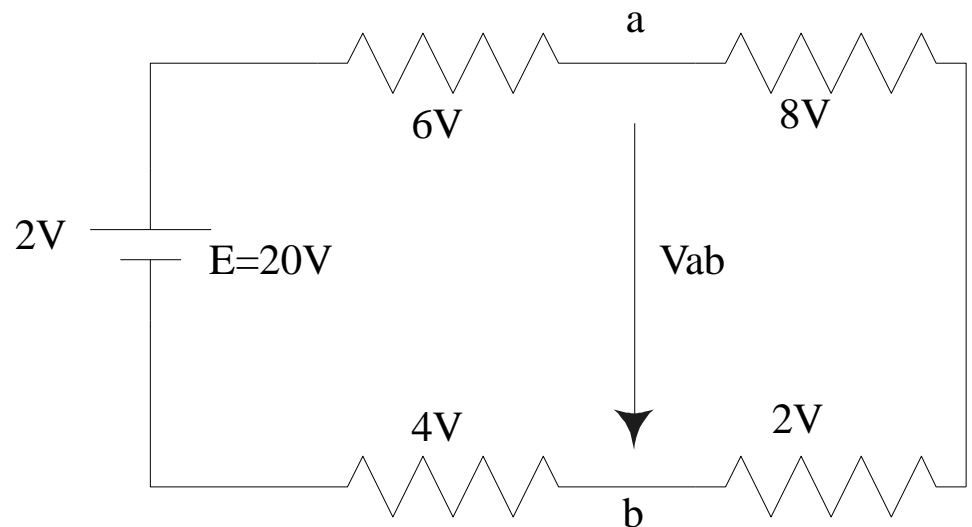
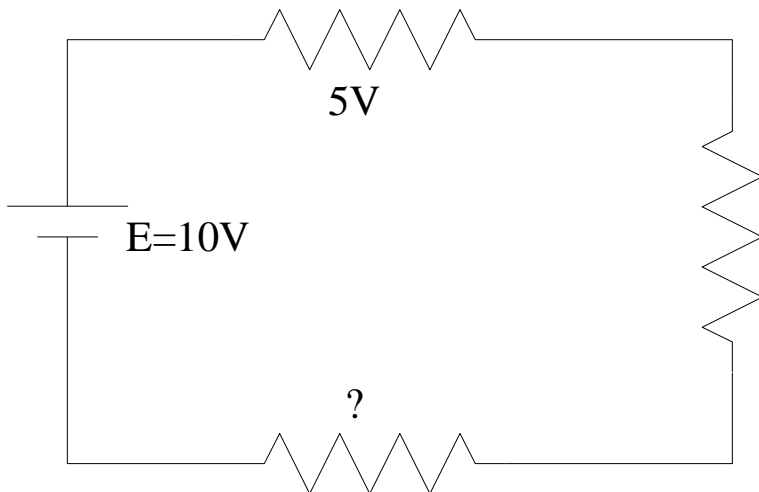

Interchanging Components

- ⌘ The components of a series circuit can be interchanged without affecting the total resistance, current or power to each component.

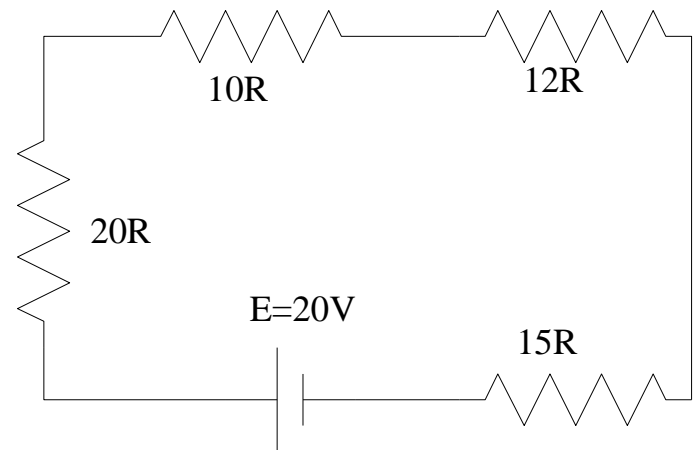
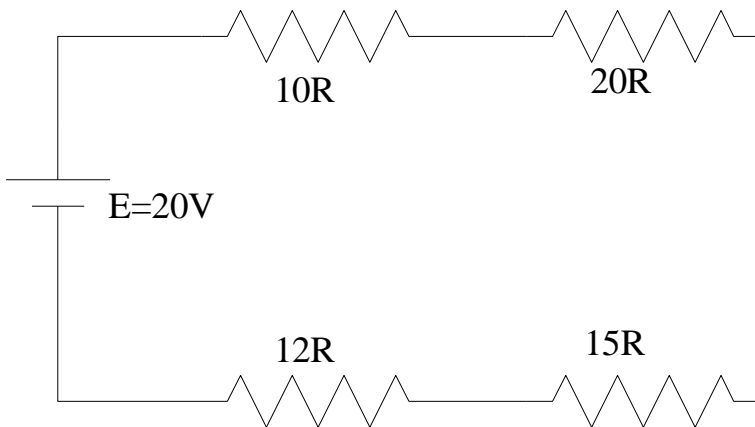

Voltage Divider Rule

$$\text{⌘ } R_T = R_1 + R_2$$

$$\text{⌘ } I = E/R_T$$

$$\text{⌘ } V_1 = IR_1 = (E/R_T).R_1 = E.R_1/R_T$$

$$\text{⌘ } V_2 = IR_2 = (E/R_T).R_2 = E.R_2/R_T$$

$$\text{⌘ } V_x = R_x.E/R_T$$

⌘ The voltage divider rule states that the voltage across a resistor in a series circuit is equal to the value of that resistor times the total voltage across the series components divided by the total resistance of the series components.

